



# FUEL SYSTEM

## Section 3B - Carburetors

### Table of Contents

---

Attenuator And Carb Throttle Levers .....	3B-2	Off-Idle Circuit .....	3B-19
Fuel Lines .....	3B-4	Main Circuit .....	3B-20
Carburetor .....	3B-6	Back Draft Circuit .....	3B-21
Fuel System - Troubleshooting .....	3B-10	Carburetor Specifications .....	3B-22
General Information .....	3B-10	Carburetor Placement and Jet Location for	
Reed Valve Leak Test .....	3B-12	Each Cylinder .....	3B-23
Thermal Air Valve Circuit Description .....	3B-13	Carburetor Jet Placement .....	3B-24
Enrichener System Description .....	3B-14	High Altitude Recommendations .....	3B-25
Manual Operation of Enrichener Valve ..	3B-14	Jet Part Number Chart .....	3B-25
Enrichener Valve Test .....	3B-15	High Altitude Jet Chart .....	3B-26
Carburetor .....	3B-16	Removing Carburetor(s) from Engine .....	3B-27
Carburetor Fuel Circuits .....	3B-17	Throttle Shaft Screws .....	3B-28
Float Bowl Circuit .....	3B-17	Float Adjustment .....	3B-28
Idle Circuit .....	3B-18	Installing Carburetor(s) to Engine .....	3B-29
Cold Start Circuit .....	3B-19		

---





# Attenuator And Carb Throttle Levers

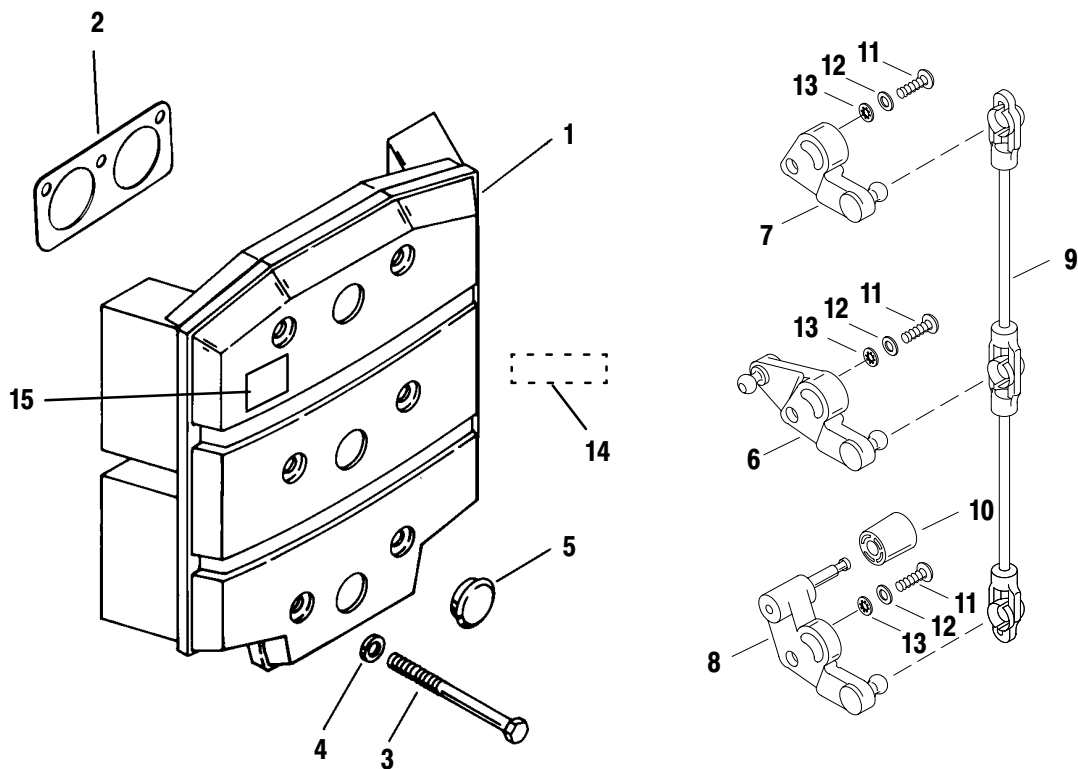



REF. NO.	QTY.	DESCRIPTION	TORQUE		
			lb-in	lb-ft	Nm.
1	1	SOUND ATTENUATOR PLATE			
2	3	GASKET			
3	6	SCREW (1/4-28 x 2-1/2)	60		7.0
4	6	WASHER			
5	3	CAP PLUG			
6	1	THROTTLE LEVER KIT			
7	1	THROTTLE LEVER			
8	1	THROTTLE LEVER			
9	1	THROTTLE LINK			
10	1	ROLLER			
11	3	SCREW (10-32 x 3/4)			
12	3	WASHER			
13	3	LOCKWASHER			
14	1	DECAL-EPA INFO (2000)(135)(SEE NOTE)			
	1	DECAL-EPA INFO (2000)(150/XR6/MAG. III/200) (SEE NOTE)			
15	1	DECAL- Caution Air Box			

**NOTE: THE EPA LABEL HAS IMPORTANT INFORMATION ON EPA EMISSION REGULATIONS. REPLACE ANY MISSING OR UNREADABLE EPA LABEL.**



# Fuel Lines

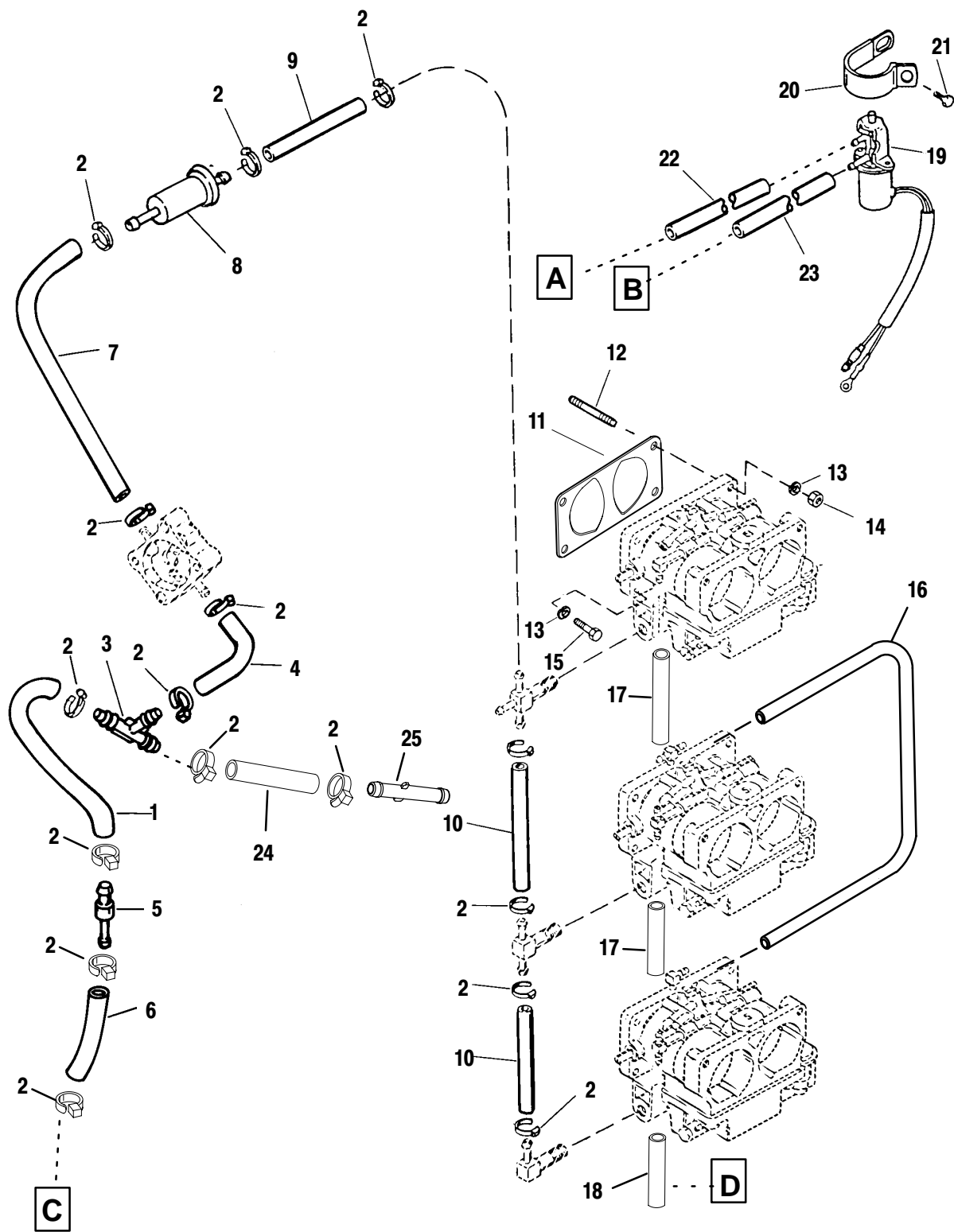

A= to top carb .. B = to middle carb ...  
 C = to oil pump . D= to Cyl. Head



# Fuel Lines

REF. NO.	QTY.	DESCRIPTION	TORQUE		
			lb-in	lb-ft	Nm.
1	1	FUEL LINE (4-1/2 IN.)			
2	AR	STA-STRAP			
3	1	TEE			
4	1	HOSE			
5	1	CHECK VALVE			
6	1	FUEL LINE (2 IN.)			
7	1	HOSE			
8	1	FUEL FILTER			
9	1	HOSE (11 IN.)			
10	2	FUEL LINE (4-1/2 IN.)			
11	3	GASKET			
12	6	STUD			
13	6	LOCKWASHER			
14	6	NUT			
15	6	SCREW (1/4-20 x 7/8)			
16	1	FUEL LINE (9 IN.)			
17	2	HOSE (4-1/4 IN.)			
18	1	HOSE (26 IN.)			
19	1	ENRICHNER VALVE			
20	1	CLAMP			
21	1	SCREW (1/4-20 x 1/2)			
22	1	FUEL LINE (4-1/2 IN.)			
23	1	HOSE (3-3/4 IN.)			
24	1	TUBING (18 IN.)			
25	1	INLINE CONNECTOR			



# Carburetor

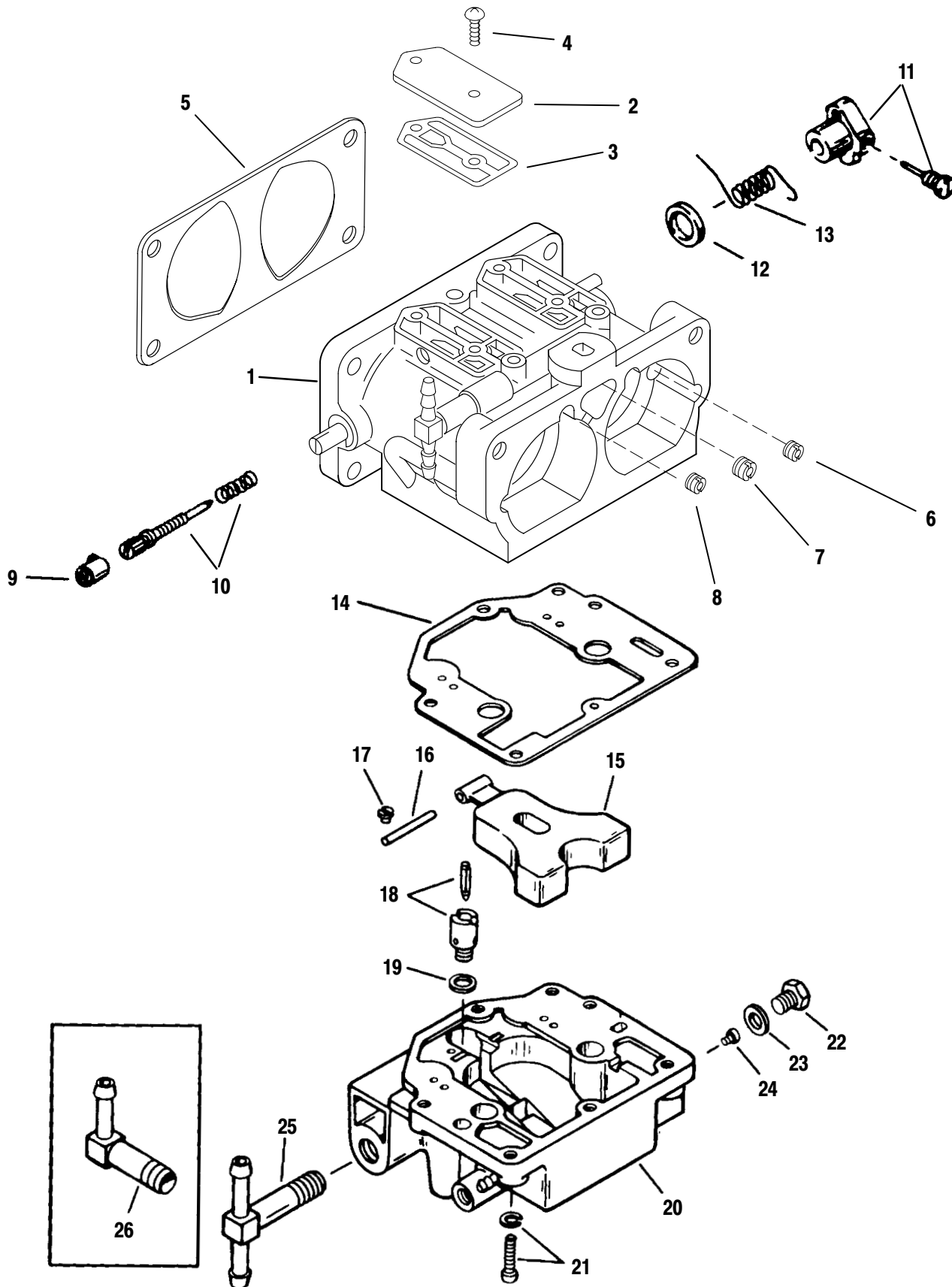



# Carburetor

REF. NO.	QTY.	DESCRIPTION	TORQUE		
			lb-in	lb-ft	Nm.
1	1	TOP CARBURETOR			
	1	CENTER CARBURETOR <b>135 - WMV-15</b>			
	1	BOTTOM CARBURETOR			
	1	TOP CARBURETOR			
	1	CENTER CARBURETOR <b>150/XR6/MAGNUM III</b>			
	1	BOTTOM CARBURETOR <b>WMV-16</b>			
	1	TOP CARBURETOR			
	1	CENTER CARBURETOR <b>200 - WMV-18</b>			
	1	BOTTOM CARBURETOR			
2	6	COVER			
3	6	GASKET			
4	12	SCREW	18		2.0
5	3	GASKET			
6	2	JET-idle air vent <b>(.040-Top/Center)(135)</b>	14		1.5
	1	JET-idle air vent <b>(.048 - Bottom)(135)</b>	14		1.5
	2	JET-idle air vent <b>(.044-Top/Center)(150/XR6/Magnum III)</b>	14		1.5
	1	JET-idle air vent <b>(.048-Bottom)(150/XR6/Magnum III)</b>	14		1.5
	1	JET-idle air vent <b>(.038-Top)(200) PORT</b>	14		1.5
	1	JET-idle air vent <b>(.028-Center)(200)</b>	14		1.5
	1	JET-idle air vent <b>(.032-Bottom)(200)</b>	14		1.5



# Carburetor

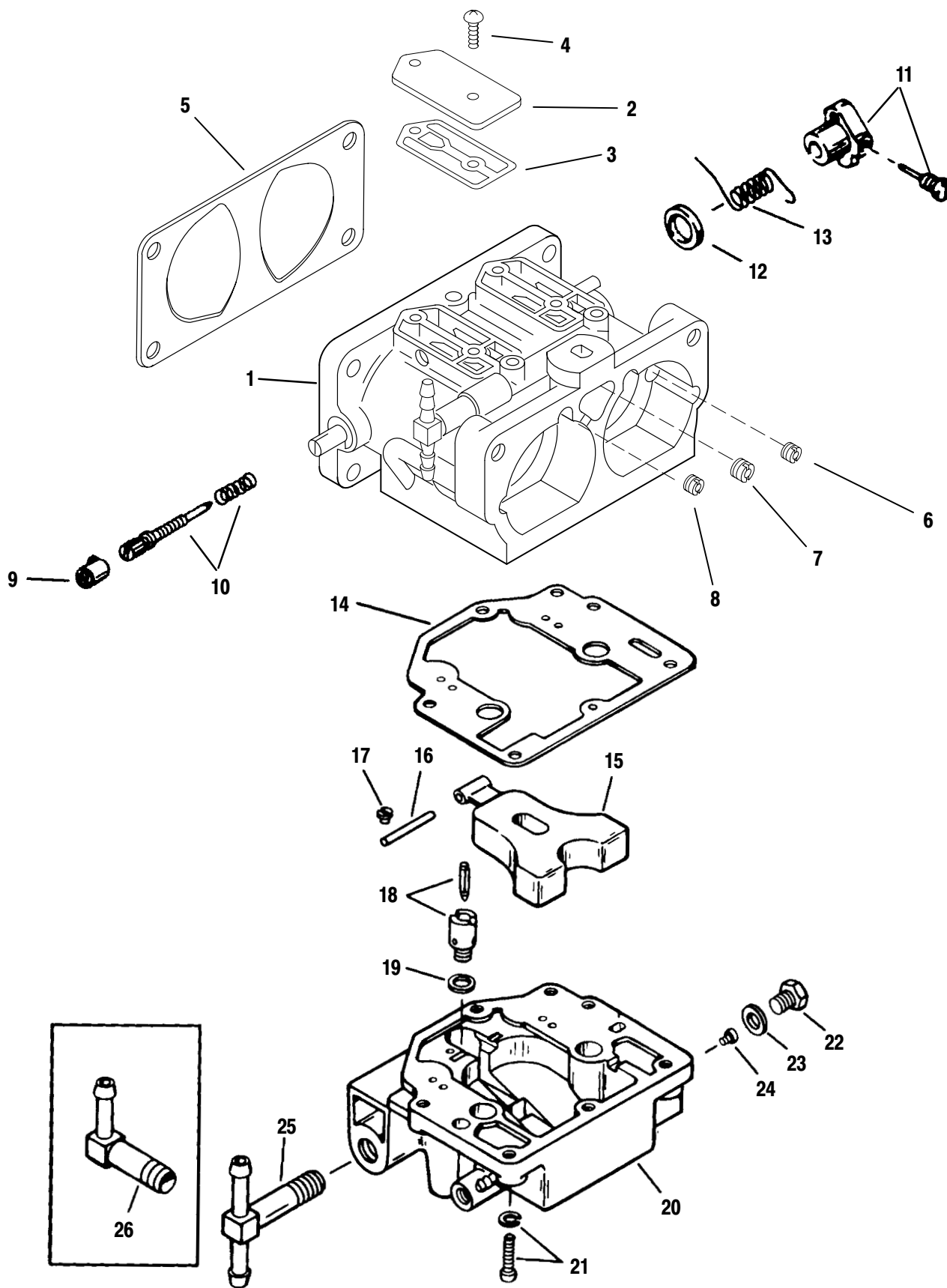





# Carburetor

REF. NO.	QTY.	DESCRIPTION	TORQUE		
			lb-in	lb-ft	Nm.
7	3	JET–bowl vent (.086)(135/200)			
	3	JET–bowl vent (.082)(150/XR6/Magnum III)			
8	1	JET–idle air vent (.036-Top)(135)			
	1	JET–idle air vent (.030-Center)(135)			
	1	JET–idle air vent (.038-Bottom)(135) STARBOARD			
	3	JET–idle air vent (.044)(150/XR6/Magnum III)			
	1	JET–idle air vent (.038-Top)(200)			
	2	JET–idle air vent (.028-Center/Bottom)(200)			
9	6	LIMITER CAP			
10	6	IDLE MIXTURE SCREW/SPRING			
11	3	LEVER KIT			
12	3	SPACER			
13	3	SPRING			
14	3	GASKET–fuel bowl			
15	3	FLOAT			
16	3	FLOAT SHAFT			
17	3	SCREW–float	10		1.0
18	3	VALVE SEAT KIT			
19	3	GASKET–valve seat			
20	1	FUEL BOWL (TOP)			
	2	FUEL BOWL (CENTER/BOTTOM)			
21	18	SCREW–fuel bowl	26		3.0
22	6	PLUG KIT	33		3.5
23	2	GASKET (Consists of 4 gaskets)			
24	6	JET–main fuel (.072)(135)	14		1.5
	6	JET–main fuel(.074)(150/XR6/Magnum III)	14		1.5
	2	JET–main fuel (.080)(200-Top-Stbd/Center-Port)	14		1.5
	2	JET–main fuel (.082)(200-Top-Port)/Center-Stbd)	14		1.5
	1	JET-main fuel (.078)(200-Bottom-Port)	14		1.5
	1	JET-main fuel (.084)(200-Bottom-Stbd)	14		1.5
25	2	TEE FITTING (TOP/CENTER)			
26	1	ELBOW (BOTTOM)			



# Fuel System - Troubleshooting

## General Information

Problems, that are thought to be caused by the fuel system, may be, in reality, something completely different. Items, that are shown in the list on the left, could give the impression that there is a problem in the fuel system.

1. Impeller
2. Spark plugs
3. Ignition timing
4. Ignition spark voltage
5. Cylinder compression
6. Reed valves

<b>Problem: Engine Turns Over But Will Not Start Or Starts Hard When Cold</b>	
<b>Possible Cause</b>	<b>Corrective Action</b>
Improper starting procedure used.	Check proper starting procedure, as outlined in "Operation and Maintenance Manual."
Fuel tank empty or too low. Improperly mixed fuel. Contaminants (water, dirt, etc.) in fuel	Check fuel in fuel tank and replace or add whichever is necessary.
Fuel tank air vent closed or restricted.	Check air vent on fuel tank. Air vent must be open all-the-way and free from any contaminants.
A pinched, cut or restricted fuel line. Also loose fuel line connection.	Check all fuel lines and replace as needed. Check and tighten all fuel line connections.
Dirty or restricted fuel filter.	Check and replace or clean all fuel filters.
Low fuel pump pressure.	Refer to Section 3A.
An anti-siphon valve.	Refer to "Checking for Restricted Fuel Flow" in Section 3A.
Choke solenoid, or enrichment valve not operating.	Check choke solenoid or valve, and electrical wiring to solenoid or valve. Replace if necessary.
A needle and seat (in carburetor) that is either stuck open or closed. Open=Flooding - Closed=Starving	Refer to "Carburetor Disassembly" in this section.
Improper carburetor jets, restricted jet or idle mixture screw out of adjustment.	Refer to "Carburetor Adjustments" in this section.
Improper carburetor float level.	Refer to "Carburetor Adjustments" in this section.



**Problem: Engine Idles Rough and Stalls.**  
**Problem: Engine Hesitates Upon Acceleration.**  
**Problem: Engine Runs Uneven or Surges.**

Possible Cause	Corrective Action
Improperly mixed fuel. Contaminants (water, dirt, etc.) in fuel.	Check fuel in fuel tank and replace if necessary.
Fuel tank air vent closed or restricted.	Check air vent on fuel tank. Air vent must be open all-the-way and free from restrictions.
A pinched, cut or restricted fuel line. Also loose fuel line connection.	Check all fuel lines and replace as needed. Check and tighten all fuel line connections.
A dirty or restricted fuel filter.	Check and replace or clean all fuel filters.
Low fuel pump pressure.	Refer to Section 3A.
An anti-siphon valve.	Refer to Section 3A.
A needle and seat (in carburetor) that is either stuck open or closed. Open=Flooding - Closed=Starving	Refer to "Carburetor Adjustments" in this section.
Improper carburetor jets, restricted jet or idle mixture screw out of adjustment.	Refer to "Carburetor Adjustments" in this section.
Improper carburetor float level.	Refer to "Carburetor Adjustments" in this section.
Carburetor loose on reed block housing.	Tighten carburetor nuts securely.
Reed block housing loose, or gaskets are defective.	Using a pressure oil can, spray 2-cycle oil around reed block housing/crankcase housing matching surfaces and carburetor base. If engine RPM changes, tighten or replace reed block housing gaskets or carburetor base gaskets, as needed.
Improperly routed or restricted bleed hose(s).	Refer to bleed line routing in this section.

## REED VALVE SPECIFICATIONS

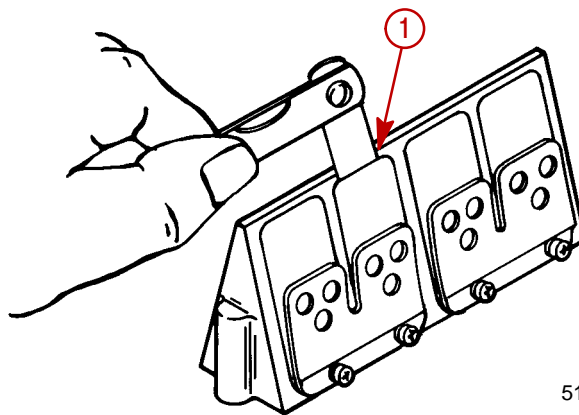

51851

### Reed Valve Opening

**1** - Max. 0.020 in. (0.59 mm)



## Reed Valve Leak Test

### TOOLS REQUIRED FOR TEST:

- a. Fuel Pressure Gauge (0 to 15 psi)[0 – 103.4 kPa]
  - b. Hose (approx. 3 ft. x 1/8 in. ID)[274 cm x 3.2 mm ID] same diameter as bleed hoses.
1. Remove engine cowling.
  2. Place outboard in water, start and allow to warm up.

**NOTE:** To gain access to cylinder #5 bleed fitting remove throttle cam from throttle linkage. Refer to “Carburetor Removal/Installation” for cam removal and installation.

3. Remove and plug bleed hoses (one at a time) from crankcase cover and connect fuel pressure gauge as shown.
4. With engine at idle, a reading of 3 – 6 psi (20.7 – 41.4 kPa) must be attained. If reading falls below 3 psi (20.7 kPa) inspect reed valves. Refer to induction manifold disassembly in Powerhead Section 4 of service manual. Replace reed valves or check valves as required.

**NOTE:** Check valve is functioning if air flows in one direction as shown.

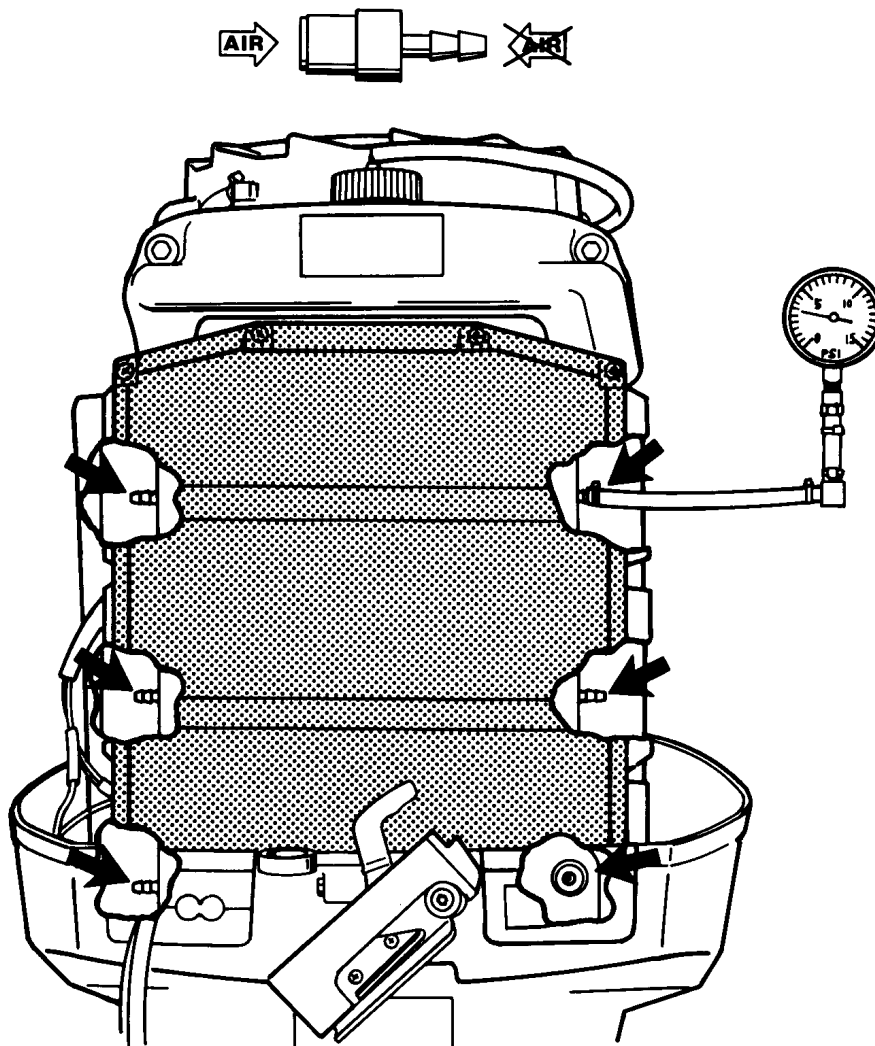



## Thermal Air Valve Circuit Description

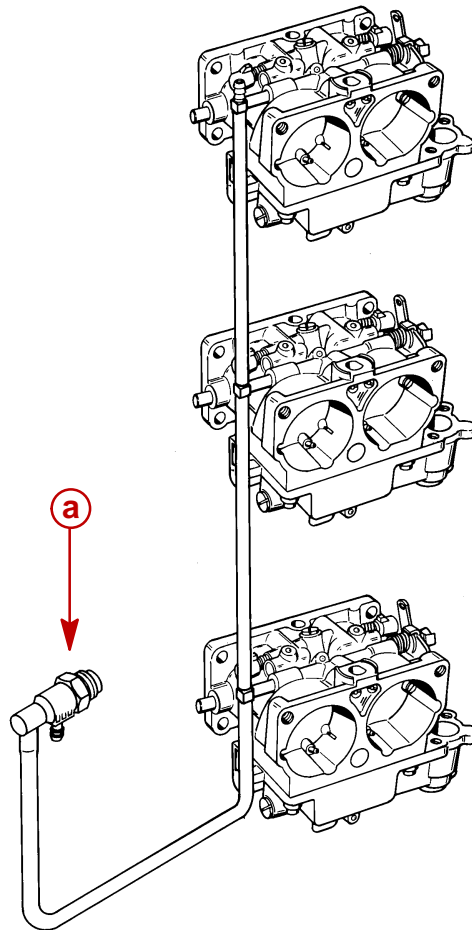

**a** - Thermal Air Valve

51863

The thermal air valve circuit functions as an air restrictor for the idle circuit which is controlled by a thermal open/close valve monitoring engine temperature. The valve is located on the starboard cylinder head below no. 3 spark plug. When the engine temperature is below 100° F (38° C) the thermal air valve is closed. When a cold engine is running, the thermal air valve restricts air to the idle circuit causing the fuel mixture to be richer. When the engine warms sufficiently, the thermal valve opens allowing required fuel/air mixture for efficient operation.



## Enrichener System Description

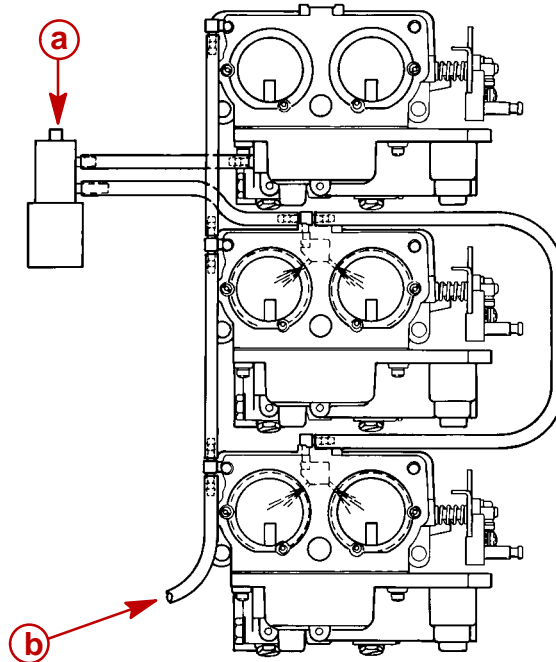

- a** - Manual Primer Button  
**b** - To Thermal Air Valve

51862

The enrichener system provides the engine with a rich fuel charge for starting ease of a cold engine. The system consists of an electrically operated enrichener valve which is connected by hoses to the carburetors.

Fuel is gravity fed to the valve from the float bowl of the top carburetor via a hose. When the key (or choke button) is pushed in (and held in) current is sent to the valve causing it to open, which allows fuel to pass thru. The fuel passes thru a hose and is supplied to the engine via fittings located on top of the middle and bottom carburetors. When the key (or choke button) is released, the valve will return to the closed position. The valve can be operated manually if valve fails to operate electrically, refer to "Manual Operation of Enrichener Valve," following.

### Manual Operation of Enrichener Valve

**IMPORTANT: Use of enrichener if engine is warm could result in engine flooding.**

Squeeze primer bulb until bulb is firm. Press button in on enrichener valve and hold approximately five seconds. Release button. Start outboard.



## Enrichener Valve Test

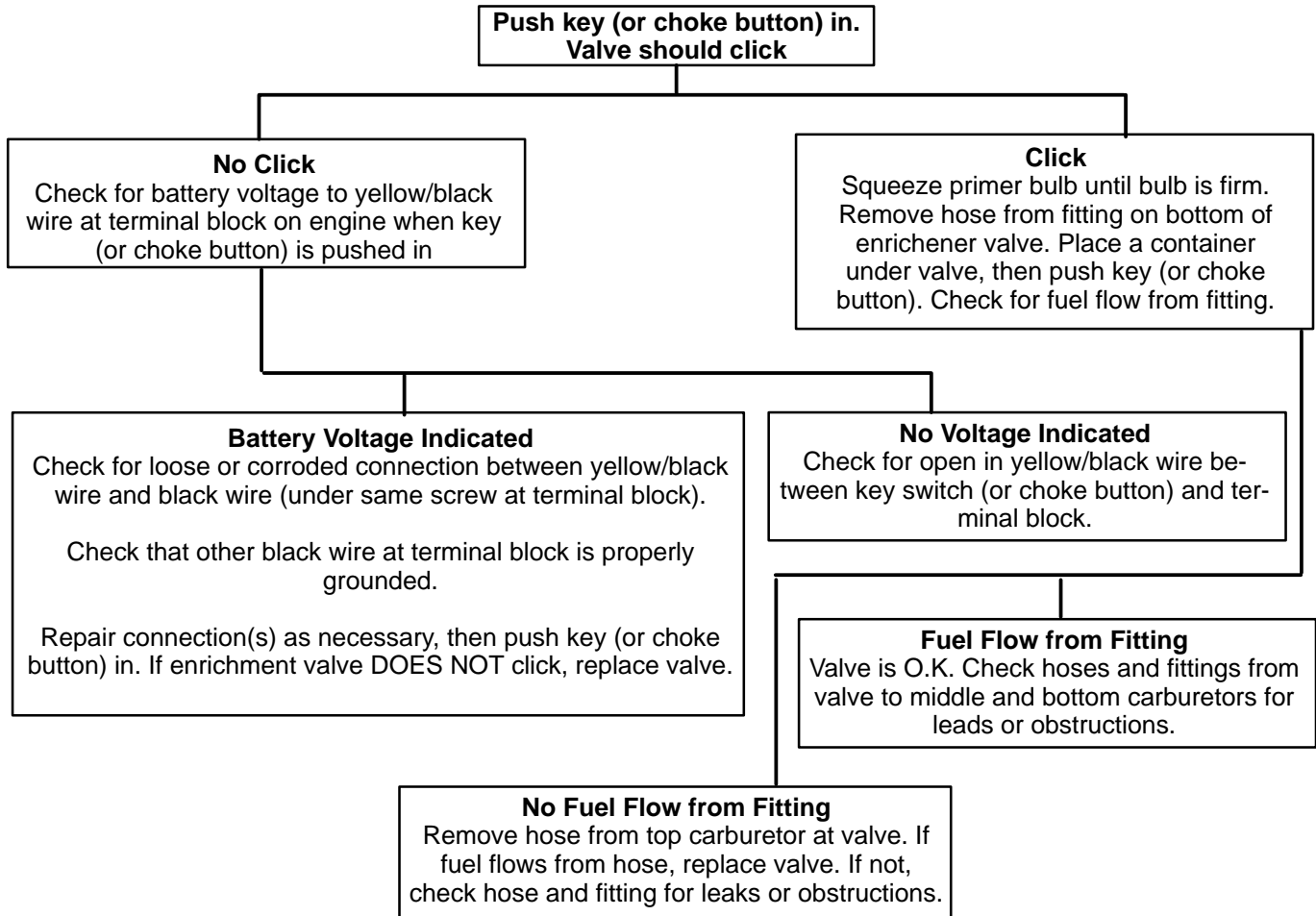

## ENRICHENER VALVE REPLACEMENT

1. Disconnect enrichener valve leads at terminal block.
2. Disconnect hoses from valve.
3. Remove bolt that secures valve mounting bracket to engine, then lift valve from engine.
4. Reinstall hoses to valve.
5. Apply a drop of Loctite 271 (92-809820) to threads of mounting bracket retaining bolt, then secure valve to engine with bracket and bolt.
6. Ground black (valve) lead by inserting terminal block retaining screw thru lead end and terminal block, and then securing to engine using screw.
7. Connect yellow/black lead (from engine harness) to yellow/black valve lead by inserting screw thru lead ends, and securing to terminal block using screw.



# Carburetor

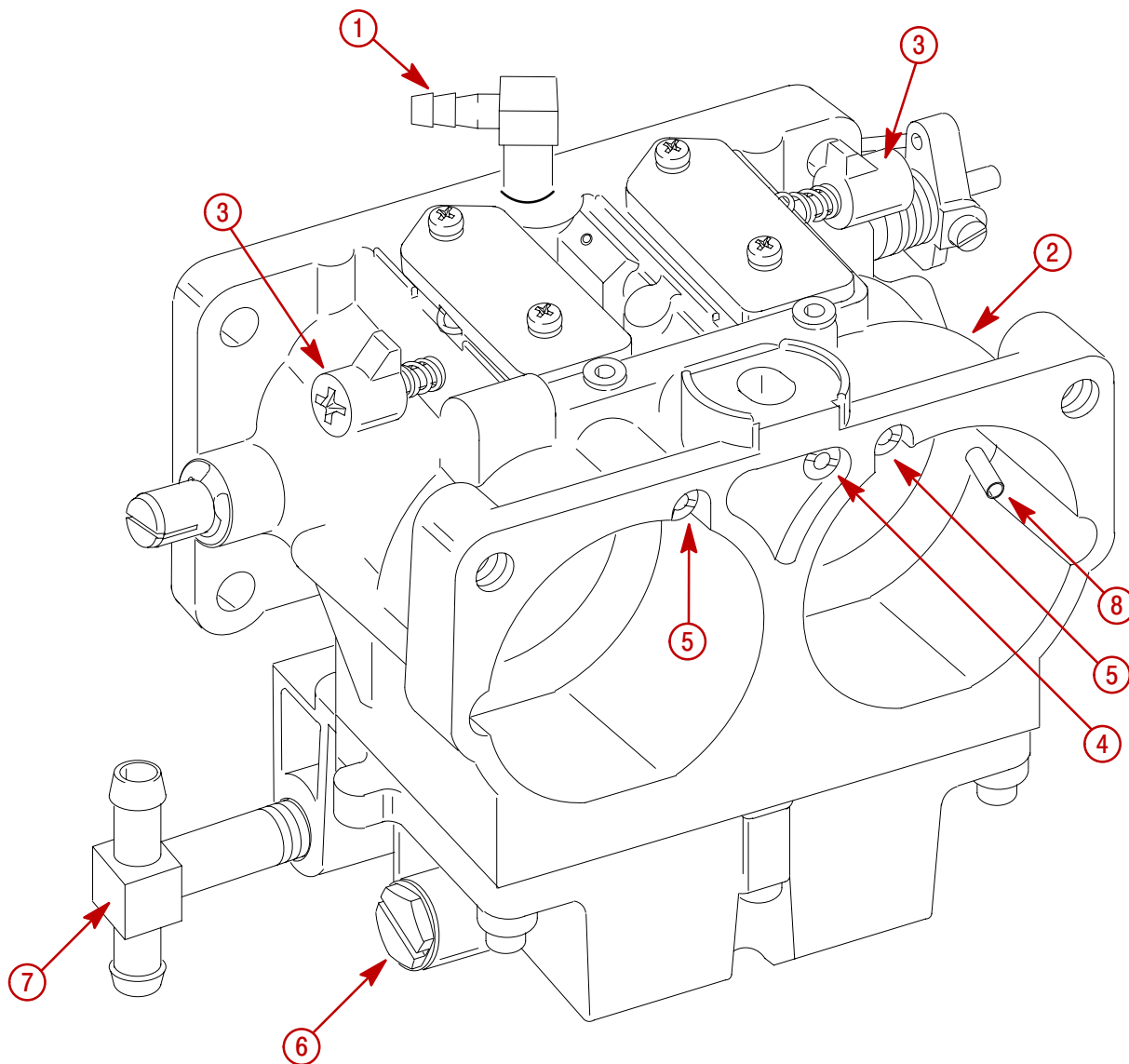

54350

- 1 - Enrichener Hose Fitting
- 2 - Carburetor Number
- 3 - Fuel Mixture Adjustment Screw
- 4 - Back Draft Vent Jet
- 5 - Idle Air Bleed Jet
- 6 - High Speed Fuel Jet Access Plug (2)
- 7 - Fuel Line Fitting
- 8 - Main Nozzle Well Vent (2)





# Carburetor Fuel Circuits

## Float Bowl Circuit

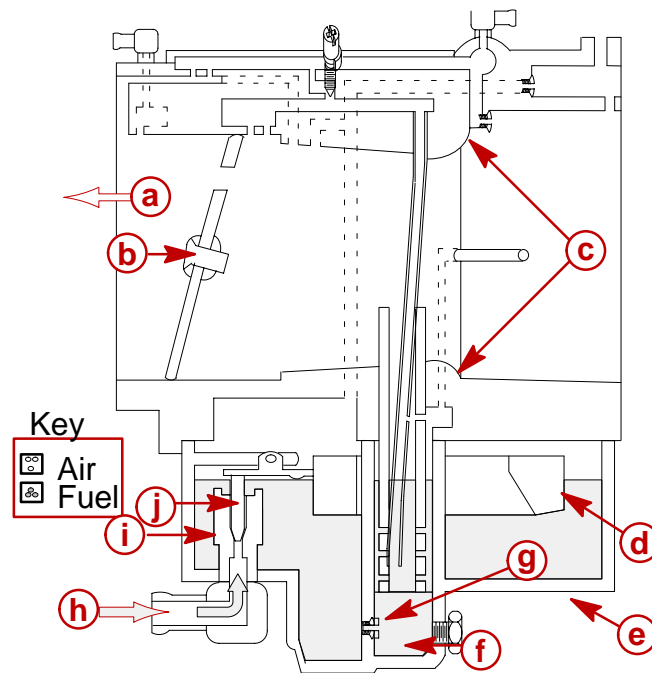

- a** - To Engine Crankcase
- b** - Throttle Plate
- c** - Carburetor Venturi
- d** - Float
- e** - Float Bowl
- f** - Main Fuel Well
- g** - Main Jet
- h** - Fuel from Fuel Pump
- i** - Inlet Seat
- j** - Inlet Needle

Fuel from the fuel pump enters the carburetor through the fuel inlet fitting and fills the bowl until the float moves the inlet needle against the fuel inlet seat. With the inlet needle against the inlet seat, the fuel inside the float bowl is at its maximum level. Fuel inside the bowl flows through the main fuel jet and fills the main fuel well.



# Idle Circuit

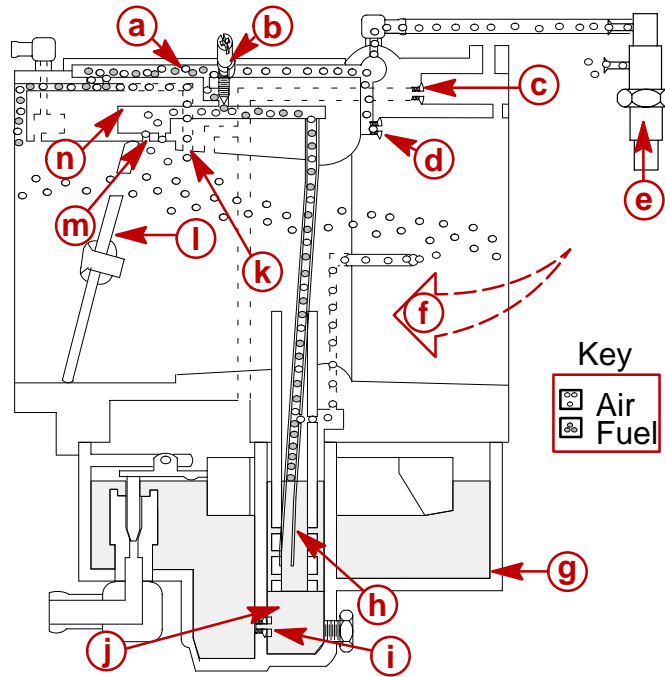

- a** - Idle Passage
- b** - Idle Mixture Screw
- c** - Back Draft Jet
- d** - Idle Air Jet
- e** - Thermal Air Valve (open)
- f** - Air Flow
- g** - Float Bowl
- h** - Idle Tube
- i** - Main Fuel Jet
- j** - Main Fuel Well
- k** - Secondary Idle Air Bleed
- l** - Throttle Plate
- m** - Off-Idle Ports
- n** - Off-Idle Passage

As the engine rotates, the piston moves away from the crankcase. This movement creates a low pressure area behind the throttle plate. Atmospheric pressure pushes air through the carburetor throat (venturi), past the throttle plate (small hole in plate) and into the low pressure area inside the crankcase. Atmospheric pressure enters the float bowl chamber through the back draft jet. This pressure forces fuel toward the low pressure area behind the throttle plate. Fuel flows:

- a. Through the main fuel jet into the main fuel well,
  - (1.) Up the idle tube,
  - (2.) Through the off-idle passages,
  - (3.) Past the idle mixture screw,
  - (4.) Into the idle passage
  - (5.) And into the carburetor throat.

Air enters the idle circuit through the idle air jet and secondary idle air bleed. This air mixes with the fuel inside the idle passage before the air/fuel mixture is discharged into the engine. Rotating the idle mixture screw will change the air/fuel mixture at idle speeds.



### Cold Start Circuit

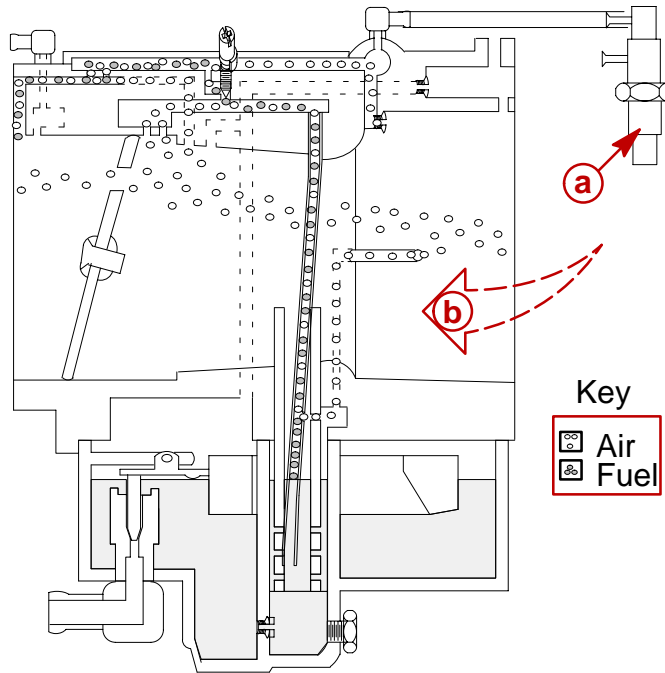

- a** - Thermal Air Valve (closed)
- b** - Air Flow

A cold engine will require a richer mixture. Fuel is supplied to the carburetors by the solenoid operated enricher valve.

### Off-Idle Circuit

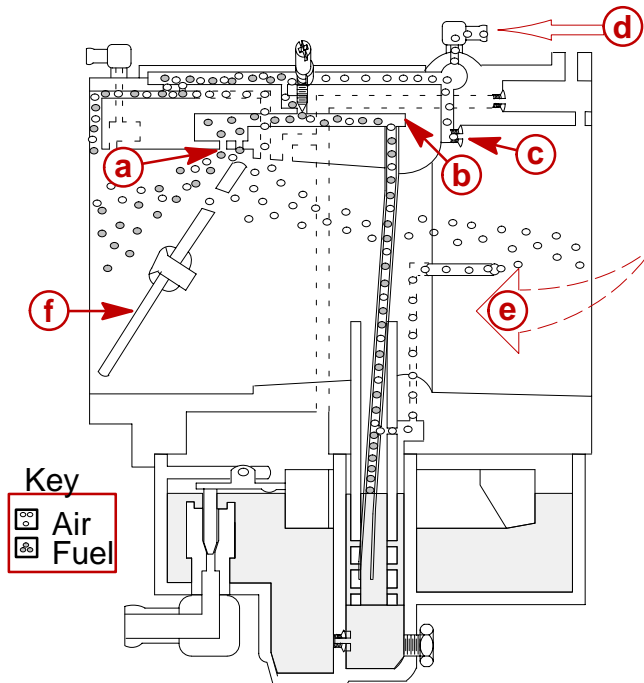

- a** - Off-Idle Ports
- b** - Off-Idle Passage
- c** - Idle Air Jet
- d** - From Open Thermal Air Valve
- e** - Air Flow
- f** - Throttle Plate



As the throttle plates rotate past the off-idle ports, the ports are exposed to the low pressure area behind the throttle plate. Additional fuel flows through the off-idle passage; through the rear port; and as the throttle plate continues to rotate, through the forward port.

## Main Circuit

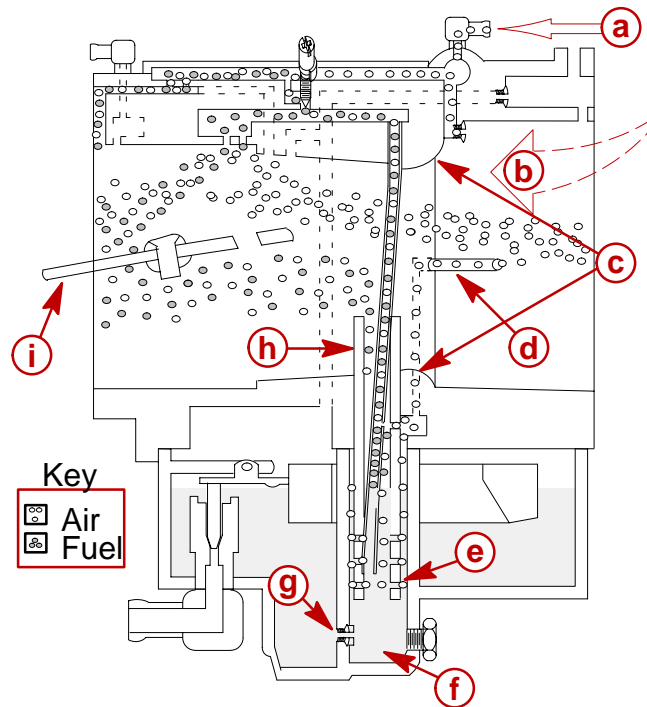

- a** - From Open Thermal Air Valve
- b** - Air Flow
- c** - Venturi
- d** - Main Discharge Air Inlet Tube
- e** - Cross Holes
- f** - Main Fuel Well
- g** - Main Fuel Jet
- h** - Main Discharge Nozzle
- i** - Throttle Plate

As the throttle plate rotates past the off-idle ports, the low pressure area extends to the main discharge nozzle. In addition, the increased air flow through the carburetor bore creates a low pressure area inside the venturi. These combined forces create a strong suction over the main discharge tube. Fuel flows:

1. Through the main fuel jet into the main fuel well,
2. Up the main discharge nozzle,
3. Into the venturi.

Air is mixed with the fuel to make it lighter, air enters the main fuel well through the main discharge air inlet tube. Cross holes are drilled in the main discharge tube, allowing the air to mix with the fuel inside the main well. As the throttling plate continues to open, additional fuel is drawn out of the main discharge tube, exposing additional cross holes. At full throttle, the fuel mixture is controlled by the size of the main fuel jet.



## Back Draft Circuit

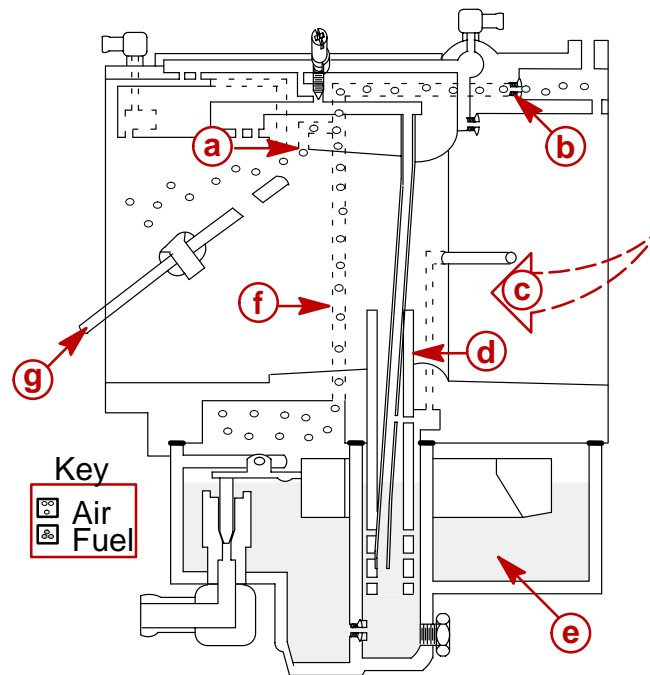

**NOTE:** Fuel Flow Not Shown For Clarity

- a** - Back Draft Port
- b** - Back Draft Jet
- c** - Air Flow
- d** - Main Discharge Tube
- e** - Fuel Bowl
- f** - Fuel Bowl Vent Passage
- g** - Throttle Plate

At partial throttle settings, the back draft circuit leans out the mixture for increased fuel economy. The back draft circuit uses the float bowl vent circuit and bowl vent jet to lean out the air/fuel mixture. The bowl vent jet limits the amount of air entering the float bowl vent circuit. With the throttle plate positioned correctly, the low pressure area is exposed to the back draft port inside the carburetor bore. The float bowl vent circuit is connected by passages to the back draft port. The low pressure area pulls air out of the bowl vent circuit. Due to the size of the vent jet and the air loss through the back draft port, the air pressure on the fuel inside the fuel bowl is lowered to below atmospheric pressure. Lower pressure on the fuel inside the float bowl, lowers the amount of fuel being forced out of the main discharge tube.



## Carburetor Specifications

### SYNCHRONIZING CARBURETORS

To synchronize carburetors, refer to “Timing/Synchronizing/Adjusting” section.

### IDLE MIXTURE SCREW

For best running quality, the adjustable idle mixture screws are set at the factory with the limit tabs pointing straight up (approx. 1-1/2 turns out for Model 135) (1-1/4 turns out for Models 150 and 200). If adjustment is required, all idle mixture screws must be turned the same amount and the same direction. Turning the idle mixture screws (recommended 1/8 turn at a time) clockwise will lean the idle mixture. Turning the idle mixture screws counter-clockwise will richen the idle mixture.

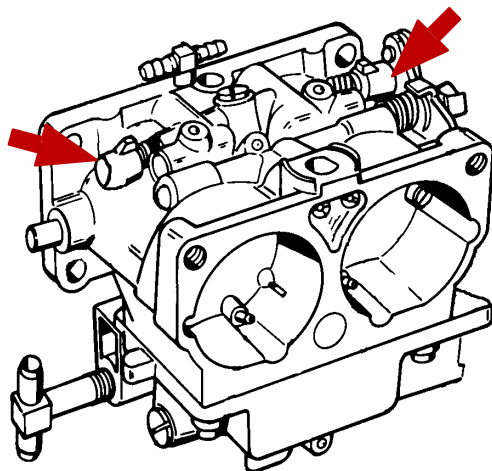

### FLOAT LEVEL ADJUSTMENT

There is one float and one float bowl for 2 cylinders. To set float height, invert float bowl and adjust float tang until top of float is even with top of float bowl.

### JET LOCATION FOR EACH CYLINDER

Carburetor jets and adjustment screw installed in the starboard side of the carburetor supply fuel to the port cylinder, jets and adjustment screw installed in the port side supply fuel to the starboard cylinder.

**NOTE:** The idle jet and back draft jet affect both cylinders.



## Carburetor Placement and Jet Location for Each Cylinder

TOP

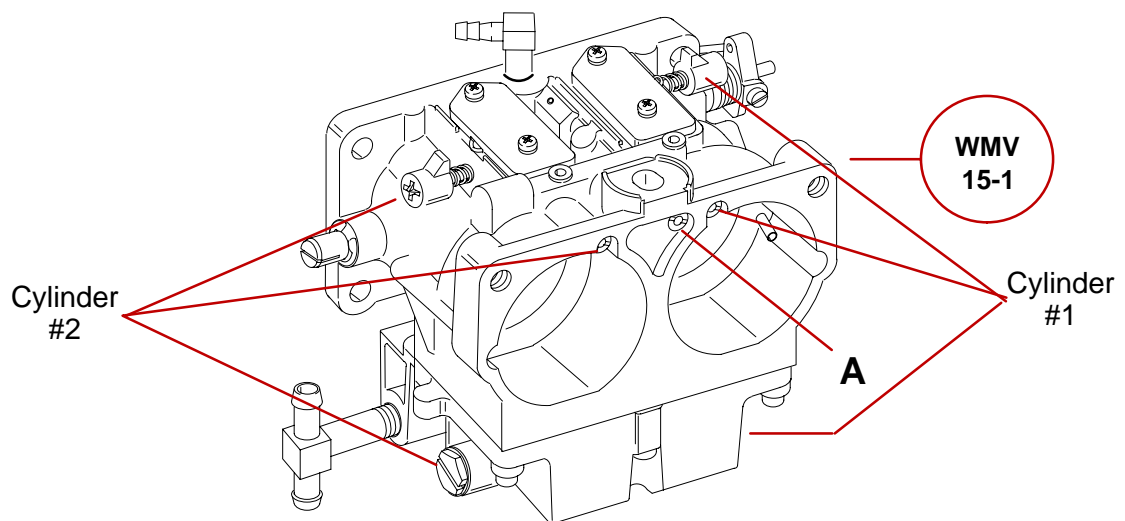

MIDDLE

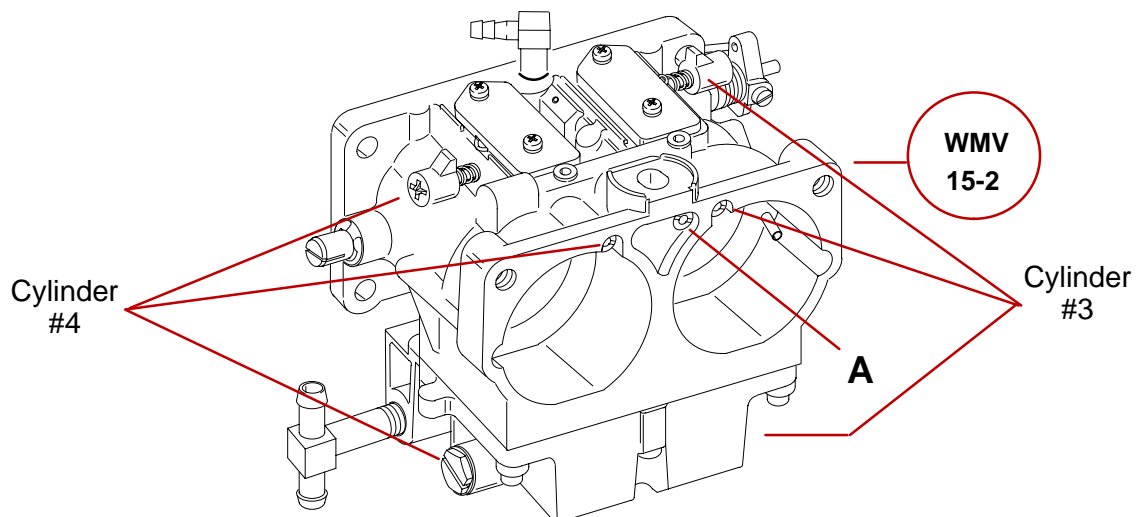

BOTTOM

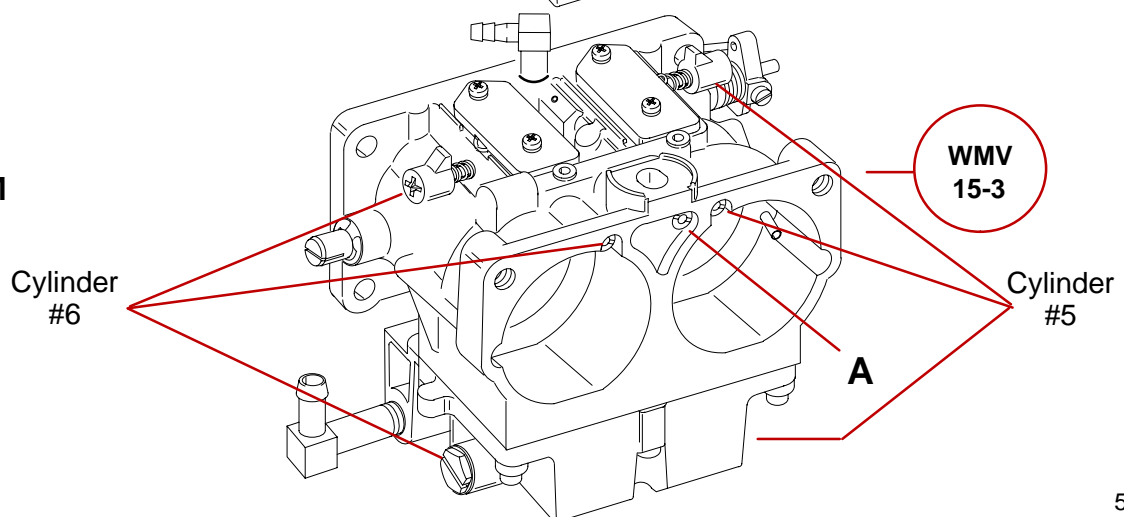

54349

### A – Backdraft Jet Affects Both Cylinders

**NOTE:** Carburetor jets and adjustment screw installed in the starboard side of the carburetor supply fuel to the port cylinder, jets and adjustment screw installed in the port side supply fuel to the starboard cylinder.



## Carburetor Jet Placement

<b>NOTE: Jets listed are for engine operation from 0–5000 feet (0–1524m) of elevation.</b>				
<b>Model 135</b>		<b>Main Jet a</b>	<b>Idle Air Bleed Jet b</b>	<b>Back Draft Vent Jet c</b>
WMV 15-1	PORT Bore	.072	.040	.086
	STBD Bore	.072	.036	
WMV 15-2	PORT Bore	.072	.040	.086
	STBD Bore	.072	.030	
WMV 15-3	PORT Bore	.072	.048	.086
	STBD Bore	.072	.038	
<b>NOTE: Jets listed are for engine operation from 0–5000 feet (0–1524m) of elevation.</b>				
<b>Model 150</b>		<b>Main Jet a</b>	<b>Idle Air Bleed Jet b</b>	<b>Back Draft Vent Jet c</b>
WMV 16-1	PORT Bore	.074	.044	.082
	STBD Bore	.074	.044	
WMV 16-2	PORT Bore	.074	.044	.082
	STBD Bore	.074	.044	
WMV 16-3	PORT Bore	.074	.048	.082
	STBD Bore	.074	.044	
<b>NOTE: Jets listed are for engine operation from 0–5000 feet (0–1524m) of elevation.</b>				
<b>Model 200</b>		<b>Main Jet a</b>	<b>Idle Air Bleed Jet b</b>	<b>Back Draft Vent Jet c</b>
WMV 18-1	PORT Bore	.082	.038	.086
	STBD Bore	.080	.042	
WMV 18-2	PORT Bore	.080	.028	.086
	STBD Bore	.082	.028	
WMV 18-3	PORT Bore	.078	.028	.086
	STBD Bore	.084	.028	

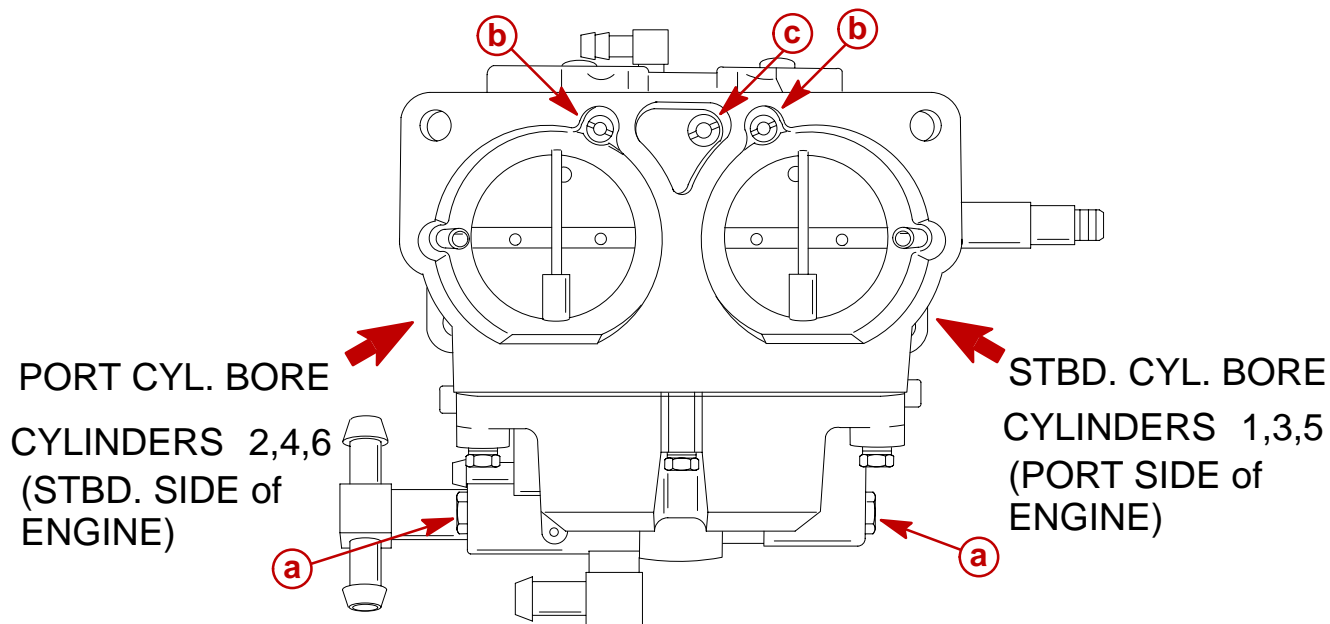





## High Altitude Recommendations

**NOTE:** Refer to "Jet Charts" for jet sizes and part numbers.

**IMPORTANT:** When operating outboard above 5000 ft. (1524m), it is recommended outboard gear ratio be reduced as shown in chart below:

Model	High Altitude Gear Ratio Change
135/150 with 2:1 Ratio	2.3:1 High Altitude Gear Kit
150 Mag III/XR6 with 1.78:1 Ratio	2:1 Complete Gearcase
150 Mag III,XR6,200 with 1.87:1 Ratio	2:1 Ratio Gear Set or Complete Gearcase

## Jet Part Number Chart

JET ORIFICE SIZE/PART NUMBER CHART 10-32							
Jet Orifice Size (inch)	Part Number	Jet Orifice Size (inch)	Part Number	Jet Orifice Size (inch)	Part Number	Jet Orifice Size (inch)	Part Number
.040	19266040	.058	1395-7831	.076	1399-3796	.094	1395-8423
.042	1399-5315	.060	1395-6487	.078	1395-6680	.096	1399-6249
.044	1395-7394	.062	1399-4217	.080	1395-6201	.098	1395-7355
.046	1399-5317	.064	1399-4216	.082	1399-3518		
.048	1395-6246	.066	1399-4215	.084	1399-3517		
.050	1395-6028	.068	1395-6029	.086	1395-5815		
.052	1395-6359	.070	1395-6030	.088	1395-6202		
.054	1399-5225	.072	1395-6207	.090	1395-6247		
.056	1399-5213	.074	1399-3794	.092	1395-5733		

JET ORIFICE SIZE/PART NUMBER CHART 8-32							
Jet Orifice Size (inch)	Part Number	Jet Orifice Size (inch)	Part Number	Jet Orifice Size (inch)	Part Number	Jet Orifice Size (inch)	Part Number
.030	810741	.038	815633038	.046	815633046	.054	815633054
.032	1399-3252	.040	1399-7570	.048	815633048	.070	815633070
.034	1395-3251	.042	815633042	.050	815633050	.076	815633076
.036	1399-3026	.044	810742	.052	815633052		

**NOTE:** Thread size for V-6 model carburetor main, idle air and back draft jets are 10-32

**NOTE:** Thread size for V-6 model carburetor progression jets are 8-32



## High Altitude Jet Chart

Factory installed main fuel jets are normally adequate for proper performance up to approximately 5000 feet (1524m) above sea level. Between 2000 feet (609.6m) and 5000 feet (1524m) the reduction of the main fuel jet(s) may result in improved performance and fuel economy. Above 5000 feet, however, it is recommended that main jet size be reduced as shown per 1000 feet (304.8m) in the following chart.

Feet Meter	1000 304.8	2000 609.6	3000 914.4	4000 1219.2	5000 1524	6000 1828.8	7000 2133.6	8000 2438.4	9000 2743.2	10000 3048	11000 352.8	12000 3657.6
Jet Size												
0.034	0.034	0.034	0.032	0.032	0.032	0.032	0.032	0.032	0.030	0.030	0.030	0.030
0.036	0.036	0.036	0.034	0.034	0.034	0.034	0.034	0.032	0.032	0.032	0.032	0.032
0.038	0.038	0.038	0.036	0.036	0.036	0.036	0.036	0.034	0.034	0.034	0.034	0.034
0.040	0.040	0.040	0.038	0.038	0.038	0.038	0.038	0.036	0.036	0.036	0.036	0.034
0.042	0.042	0.042	0.040	0.040	0.040	0.040	0.038	0.038	0.038	0.038	0.038	0.036
0.044	0.044	0.044	0.042	0.042	0.042	0.042	0.040	0.040	0.040	0.040	0.038	0.038
0.046	0.046	0.046	0.044	0.044	0.044	0.044	0.042	0.042	0.042	0.042	0.040	0.040
0.048	0.048	0.048	0.046	0.046	0.046	0.046	0.044	0.044	0.044	0.042	0.042	0.042
0.050	0.050	0.050	0.048	0.048	0.048	0.046	0.046	0.046	0.046	0.044	0.044	0.044
0.052	0.052	0.050	0.050	0.050	0.050	0.048	0.048	0.048	0.048	0.046	0.046	0.046
0.054	0.054	0.052	0.052	0.052	0.052	0.050	0.050	0.050	0.048	0.048	0.048	0.048
0.056	0.056	0.054	0.054	0.054	0.054	0.052	0.052	0.052	0.050	0.050	0.050	0.048
0.058	0.058	0.056	0.056	0.056	0.056	0.054	0.054	0.054	0.052	0.052	0.052	0.050
0.060	0.060	0.058	0.058	0.058	0.056	0.056	0.056	0.054	0.054	0.054	0.052	0.052
0.062	0.062	0.060	0.060	0.060	0.058	0.058	0.058	0.056	0.056	0.056	0.054	0.054
0.064	0.064	0.062	0.062	0.062	0.060	0.060	0.060	0.058	0.058	0.058	0.056	0.056
0.066	0.066	0.064	0.064	0.064	0.062	0.062	0.062	0.060	0.060	0.060	0.058	0.058
0.068	0.068	0.066	0.066	0.066	0.064	0.064	0.064	0.062	0.062	0.060	0.060	0.060
0.070	0.070	0.068	0.068	0.068	0.066	0.066	0.064	0.064	0.064	0.062	0.062	0.062
0.072	0.072	0.070	0.070	0.070	0.068	0.068	0.066	0.066	0.066	0.064	0.064	0.062
0.074	0.074	0.072	0.072	0.070	0.070	0.070	0.068	0.068	0.068	0.066	0.066	0.064
0.076	0.076	0.074	0.074	0.072	0.072	0.072	0.070	0.070	0.068	0.068	0.068	0.066
0.078	0.078	0.076	0.076	0.074	0.074	0.074	0.072	0.072	0.070	0.070	0.068	0.068
0.080	0.080	0.078	0.078	0.076	0.076	0.076	0.074	0.074	0.072	0.072	0.070	0.070
0.082	0.082	0.080	0.080	0.078	0.078	0.076	0.076	0.076	0.074	0.074	0.072	0.072
0.084	0.084	0.082	0.082	0.080	0.080	0.078	0.078	0.076	0.076	0.076	0.074	0.074
0.086	0.086	0.084	0.084	0.082	0.082	0.080	0.080	0.078	0.078	0.076	0.076	0.074
0.088	0.088	0.086	0.086	0.084	0.084	0.082	0.082	0.080	0.080	0.078	0.078	0.076
0.090	0.090	0.088	0.088	0.086	0.086	0.084	0.084	0.082	0.082	0.080	0.080	0.078
0.092	0.092	0.090	0.090	0.088	0.088	0.086	0.086	0.084	0.084	0.082	0.082	0.080
0.094	0.094	0.092	0.092	0.090	0.090	0.088	0.088	0.086	0.086	0.084	0.084	0.082
0.096	0.096	0.094	0.094	0.092	0.092	0.090	0.090	0.088	0.086	0.086	0.084	0.084
0.098	0.098	0.096	0.096	0.094	0.092	0.092	0.090	0.090	0.088	0.088	0.086	0.086



## Removing Carburetor(s) from Engine

1. Remove top cowling.

**IMPORTANT:** Place an identifying mark on each carburetor before removal as each carburetor must be reinstalled in same location from which removed.

**NOTE:** As each carburetor is removed from intake manifold, their respective fuel enrichment hose should be disconnected.

2. Remove air box cover and heat shield from engine.
3. Remove throttle linkage from throttle levers as shown.
4. Remove oil pump link rod from throttle lever.

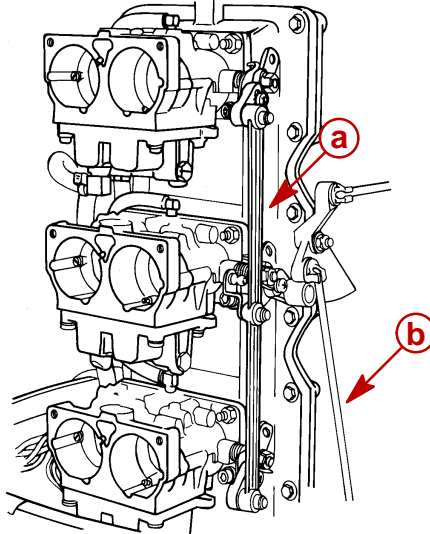

- a - Throttle Linkage
- b - Oil Pump Link Rod

5. Remove fuel hose and fuel enrichment valve hose from carburetors.

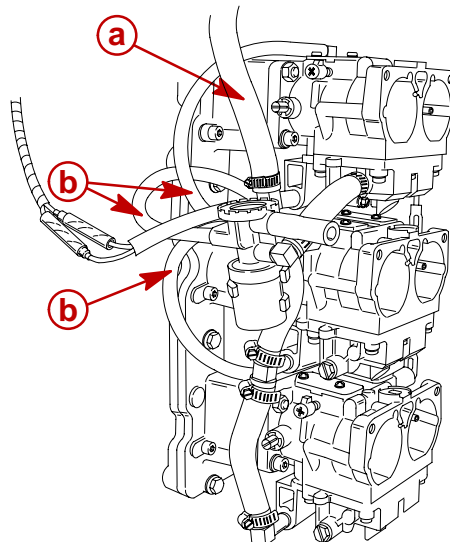

- a - Fuel Hose
- b - Enrichment Valve Hoses

6. Carburetors may now be removed individually. Mark location of each carburetor and reinstall in same location. Remove carburetor(s) secured by two nuts and two allen head type bolts.



## Throttle Shaft Screws

**NOTE:** It is recommended that the screws securing the throttle plates to the throttle shaft **NOT BE REMOVED** due to the difficulty in obtaining correct alignment of throttle plates during reassembly. If screws must be removed, apply Loctite 271 to screw threads before reinstalling screws.

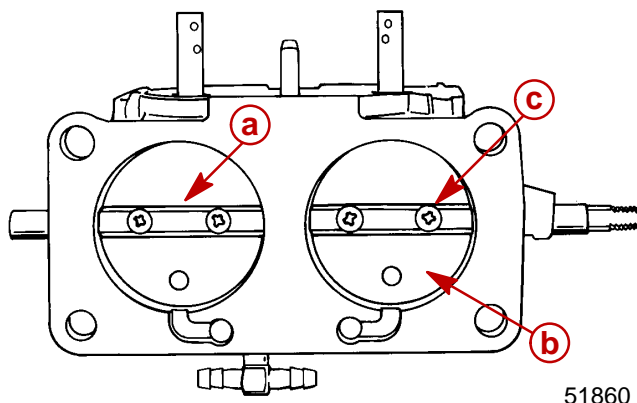

- a** - Throttle Shaft
- b** - Throttle Shutter Plate
- c** - Screws

## Float Adjustment

**NOTE:** Float height adjustment is the only adjustment made to adjust float setting.

1. Adjust float height by turning fuel bowl upside-down, then adjust float tab until float is level with edge of fuel bowl. Adjust float tab if necessary.

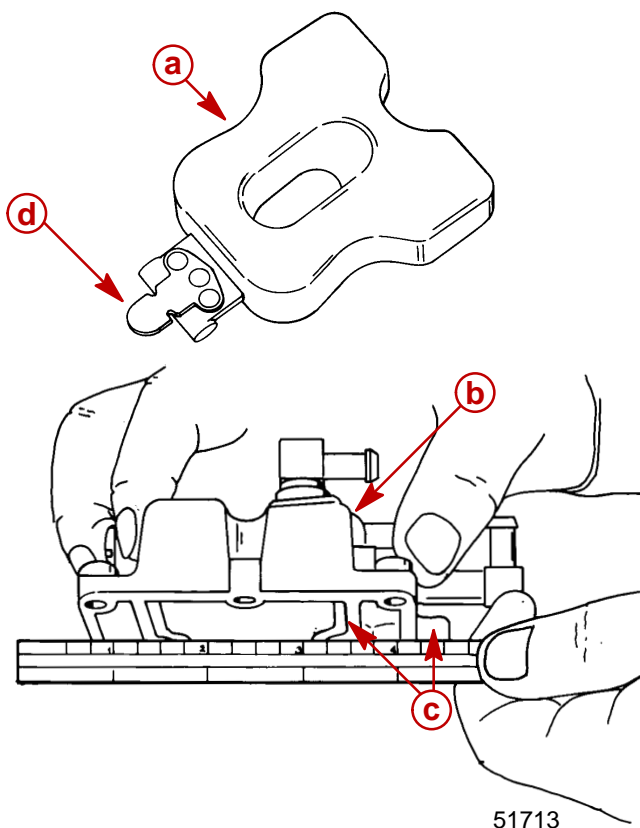

- a** - Float (Adjust by bending tab)
- b** - Fuel Bowl (Upside-Down)
- c** - Float Level Even with Bowl Edge
- d** - Float Tab



## Installing Carburetor(s) to Engine

1. Place new carburetor gaskets onto carburetor mounting studs on intake manifold.
2. Install carburetors (in respective locations) onto mounting studs and secure in place with nuts and allen type bolts.
3. Connect enrichment hoses and fuel hoses. Secure hoses in place using sta-straps.

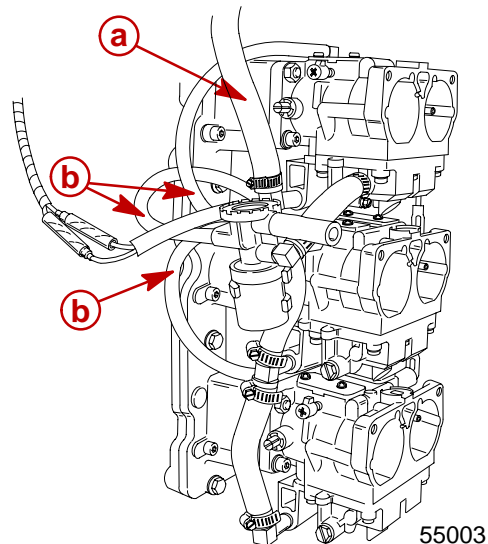

- a** - Fuel Hose  
**b** - Enrichment Valve Hose

4. Attach throttle linkage and oil pump link rod to carburetors as shown.

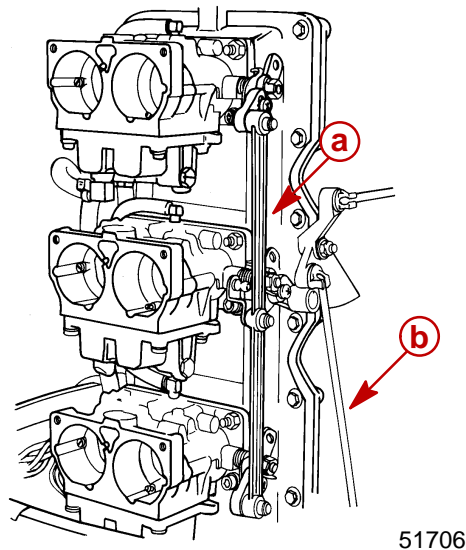

- a** - Throttle Linkage  
**b** - Oil Pump Link Rod

5. Re-synchronize carburetors following carburetor installation. Refer to “Timing/Synchronizing/Adjusting” Section 2C.

**IMPORTANT:** Inspect all fuel hose connections, and carburetor float bowl split lines for fuel leaks with engine running. Also inspect each carburetor throat, with out-board running at low RPM, for fuel dribbling out of vent tube which would be indicative of a float and/or needle and seat assembly not functioning properly.

**IMPORTANT:** Engine should not be operated above 3000 RPM with air box cover removed as engine will run too lean and internal damage could result.